

FS 816-15 DS

Single Convolution Air Actuator

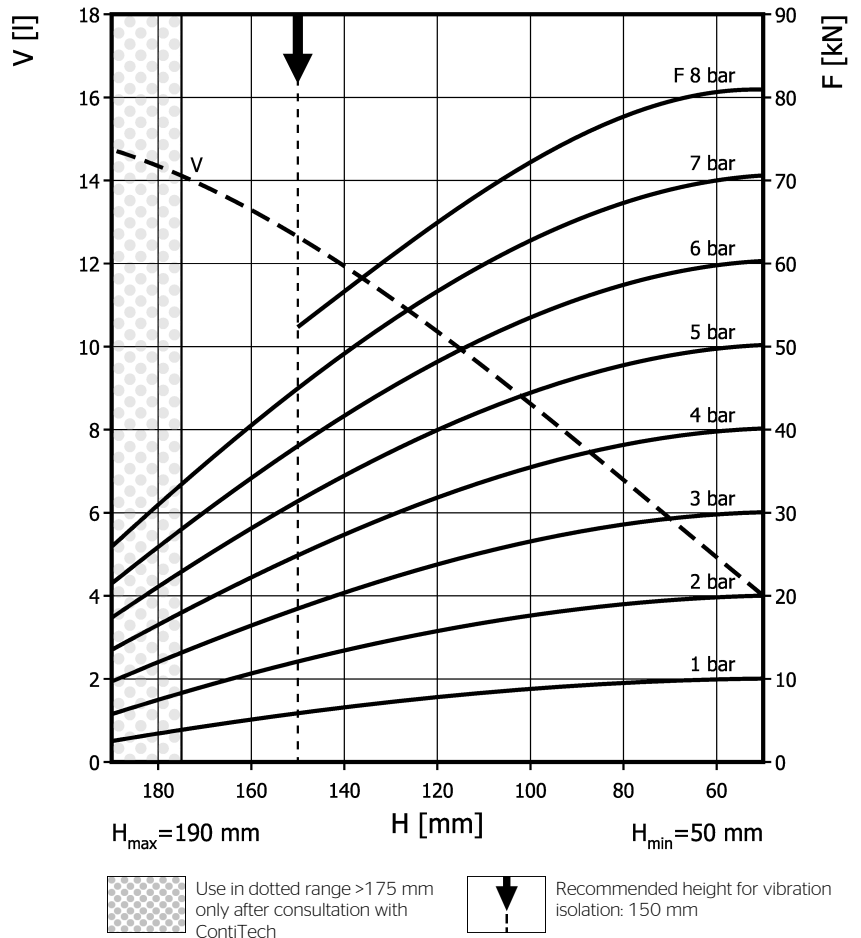
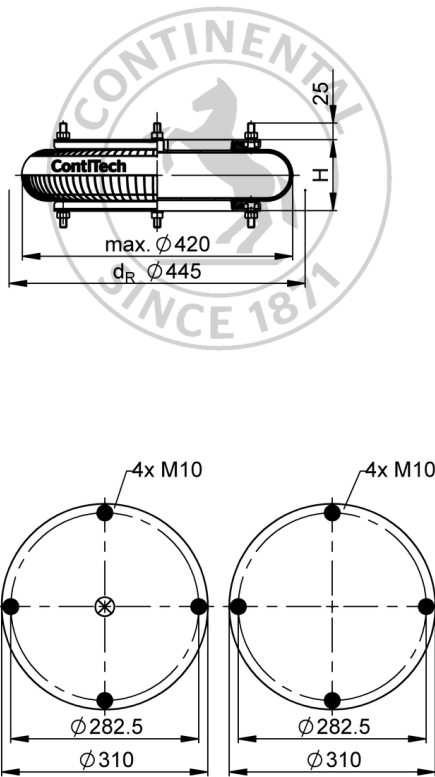

Purchase order data

Type	Order No.
rubber bellows only	69687
with dismountable plates, G1/2 air inlet	70043

Additional types on request

Technical data

Min. pressure	0 bar
Return force to min height	≤ 30 N
Overall weight	7.6 kg

Vibration isolation - dynamic characteristic values

Design height H: recommended 150mm, minimum 130mm

Pressure p [bar]	3	4	5	6	7	8	Vol. V [l]
Force (Load) [kN]	18.9	25.3	32	38.5	45	51.3	
Spring rate [N/mm]	382	485.5	589	692.5	796	891.5	
Natural frequency [Hz]	2.2	2.2	2.1	2.1	2.1	2.1	

Pneumatic application - static characteristic values

Force F [kN]

Pressure p [bar]	3	4	5	6	7	8	Vol. V [l]
Height H [mm]	170	14.4	19.6	24.9	30.4	36.1	
	130	21.9	29.4	37	44.7	52.7	11
	100	26.5	35.4	44.4	53.4	62.7	8.6
	80	28.7	38.3	47.9	57.5	67.4	6.8
	60	30.1	40.1	50.1	60.2	70.5	4.9

 Service instructions
 M10: max. 25 Nm
 G1/2: max. 25 Nm

Measuring procedure: Room temperature / Force-height-data quasistatic / Dynamic data at 1 Hz