

SZ 100-11

Sleeve Type Air Actuator

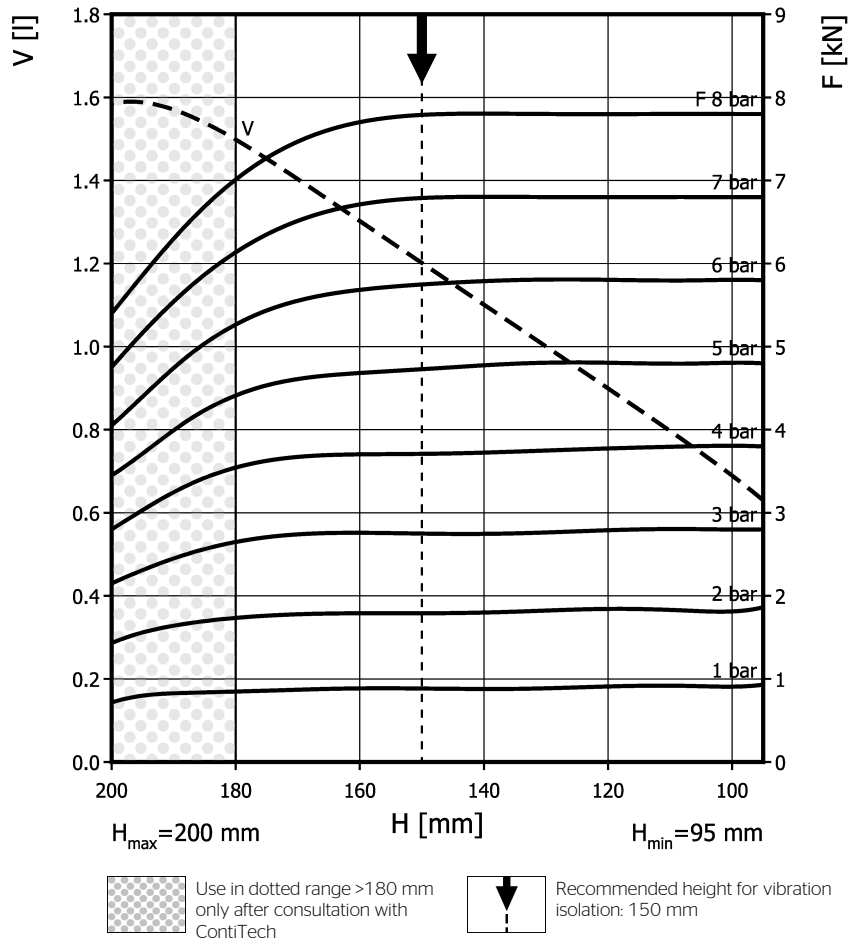
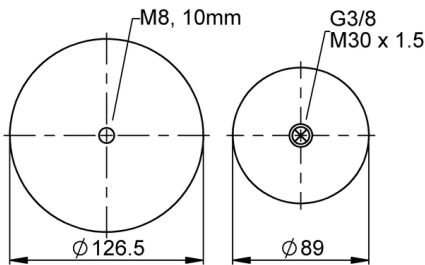
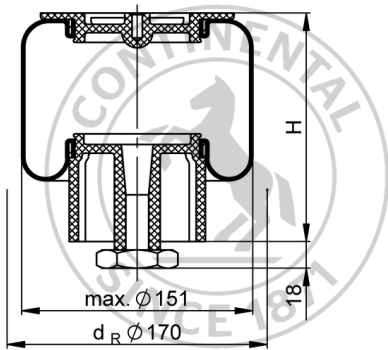

Purchase order data
Technical data

Type	Order No.
with plastic connecting parts, G3/8 air inlet	2687045000

Additional types on request

Min. pressure	0.9 bar
Return force to min height	≤ 900 N
Overall weight	0.7 kg

Vibration isolation - dynamic characteristic values

Design height H: recommended 150mm, guidance in lateral direction required

Pressure p [bar]	3	4	5	6	7	8	Vol. V [l]
Force (Load) [kN]	2.8	3.7	4.7	5.7	6.8	7.8	
Spring rate [N/mm]	43.5	54.5	65.5	76.5	87.5	98.5	
Natural frequency [Hz]	2.0	1.9	1.9	1.8	1.8	1.8	

Pneumatic application - static characteristic values

Force F [kN]

Pressure p [bar]	3	4	5	6	7	8	Vol. V [l]	
Height H [mm]	175	2.7	3.6	4.55	5.45	6.4		7.3
	160	2.75	3.7	4.7	5.7	6.7		7.7
	145	2.75	3.7	4.75	5.8	6.8		7.8
	130	2.75	3.75	4.8	5.8	6.8		7.8
	115	2.8	3.8	4.8	5.8	6.8		7.8
	100	2.8	3.8	4.8	5.8	6.8	7.8	



Service instructions
 M30x1.5: max. 40 Nm
 M8: max. 5 Nm
 G3/8: max. 10 Nm

Measuring procedure: Room temperature / Force-height-data quasistatic / Dynamic data at 1 Hz