

E Series Air Preparation Unit



How to Order?

Series No.	Type Code	Body Size	Combination	QTY	Port Size	Drain Type	Pressure Gauge Code	Bracket Code	Scale Unit	Filter Precision	Thread Type
E: Round gauge series			10: Two units (Regulator+Lubricator)			Blank: Manual drain type C: Semi-auto drain D: Auto Drain type	Blank: With pressure gauge N: No pressure gauge	Blank: With bracket J: No bracket	Blank: 25 µm 5M: 5 µm	Blank: 25 µm 5M: 5 µm	Blank: G P: PT T: NPT
C: Filter+regulator+lubricator	10: 1000 body		1000 M5: M5		4000 03: 3/8"				4: Mpa/Psi(Default)		
W: Filter+regulator	20: 2000 body		2000 01: 1/8"		04: 1/2"				5: Bar/Psi		
F: Filter	30: 3000 body		02: 1/4"		06: 3/4"						
R: Regulator	40: 4000 body		3000 02: 1/4"		5000 06: 3/4"						
L: Lubricator	50: 5000 body		03: 3/8"		10: 1"						

Order Example:

E series regulator, 2000 body size, 1/8 port size, with pressure gauge, with bracket, scale unit is Mpa/Psi, G thread, ERP code is: ER2000-01 4

Note: 2000 Series is optional for manual /auto drain type;

Standard 3000/4000/5000 Series are optional for manual/semi-auto/semi-auto integrated drain type.

Air Preparation Unit Kits

ER

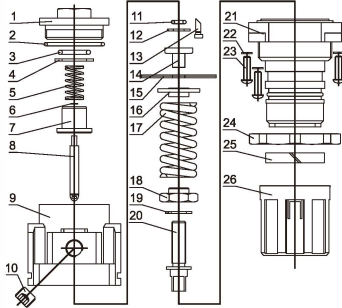

NO.	NAME	QTY	MATERIAL
26	Regulate handle	1	Reinforce nylon
25	Symbol ring	1	Reinforce nylon
24	Nut	1	Reinforce nylon
23	Cross screw	4	Carbon steel
22	Spring washer	4	Carbon steel
21	Valve cover	1	Reinforce nylon
20	Regulate bolt	1	Carbon steel
19	Washer	1	POM
18	Regulate Nut	1	Carbon steel
17	Spring	1	Carbon steel
16	Spring seat	1	Carbon steel
15	Diaphragm	1	NBR
14	Diaphragm seat	1	Brass
13	Pipe	1	POM
12	Retainer ring	1	Carbon steel
11	O-ring	1	NBR
10	Plug	1	Carbon steel
9	Valve body	1	Aluminum
8	Spool	1	Brass+NBR
7	Valve core	1	Brass
6	Retain er ring	1	Carbon steel
5	Spring	1	Stainless steel
4	Washer	1	Carbon steel
3	O-ring	1	NBR
2	O-ring	1	NBR
1	Regulator seat	1	ZZnAl-1

EF

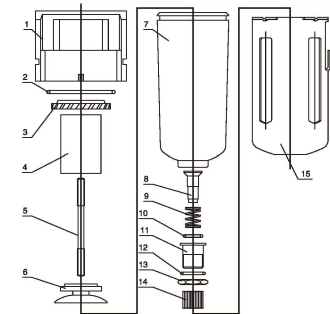

NO.	NAME	QTY	MATERIAL
18	Lock	1	ABS
17	Pin	1	ABS
16	Spring	1	Stainless steel
15	Metal bowl	1	Carbon steel
14	Nut	1	Cu
13	Hex Nut	1	Cu
12	O-ring	1	NBR
11	Drain valve	1	Cu
10	O-ring	1	NBR
9	Spring	1	Stainless steel
8	Valve core	1	Cu
7	Watercup	1	Polyarbonate
6	Drain board	1	ABS
5	Bolt	1	Carbon steel
4	Filter element	1	Cu
3	Blade	1	ABS
2	O-ring	1	NBR
1	Regulator body	1	Aluminum

EL

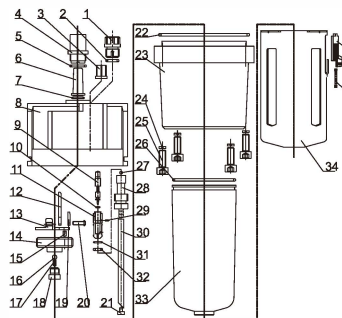

NO.	NAME	QTY	MATERIAL
37	Lock	1	ABS
36	Pin	1	ABS
35	Spring	1	Stainless steel
34	Bow guard	1	Carbon steel
33	Oil cup	1	Polyarbonate
32	O-ring	1	NBR
31	O-ring	1	NBR
30	Oil tube	1	PU
29	Pin	1	Carbon steel
28	Fitting	1	POM
27	Steel ball	1	Carbon steel
26	O-ring	1	NBR
25	Hex screw	4	Carbon steel
24	Spring washer	4	Carbon steel
23	Middle part	1	Aluminum
22	O-ring	1	NBR
21	Filter element	1	Brass
20	Screw	2	Carbon steel
19	Reeds seat board	1	ZZnAl-1
18	Oil way valve plate	1	Cu
17	Spring	1	Stainless steel
16	Steel ball	1	Carbon steel
15	Small holes seat	1	Brass
14	Bracket	1	ZZnAl-1
13	Reeds seat	1	ZZnAl-1
12	Reed	1	Polyarbonate
11	Oil regulate valve seat	1	Brass
10	O-ring	1	NBR
9	Regulate needle	1	Brass
8	Lubricator body	1	Aluminum
7	O-ring	1	NBR
6	Oil drop tube	1	Polyarbonate
5	O-ring	1	NBR
4	Oil window	1	Polyarbonate
3	Oil regulate screw	1	ABS
2	O-ring	1	NBR
1	Plug	1	ABS

EW

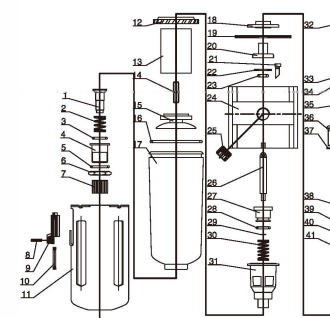

NO.	NAME	QTY	MATERIAL
41	Spring	1	Carbon steel
40	Regulate Nut	1	Carbon steel
39	Washer	1	POM
38	Regulate Bolt	1	Carbon steel
37	Spring washer	4	Carbon steel
36	Cross screw	4	Carbon steel
35	Valve cover	1	Reinforce nylon
34	Nut	1	Reinforce nylon
33	Symbol ring	1	Reinforce nylon
32	Regulate handle	1	Reinforce nylon
31	Overflow valve seat	1	ZZnAl-1
30	Spring	1	Stainless steel
29	Retainer ring	1	Carbon steel
28	O-ring	1	NBR
27	Valve core	1	Brass
26	Spool	1	Brass+NBR
25	Plug	1	Carbon steel
24	Regulator Body	1	Aluminum
23	O-ring	1	NBR
22	Retain er ring	1	Carbon steel
21	Pipe	1	POM
20	Diaphragm seat	1	Brass
19	Diaphragm	1	NBR
18	Diaphragm Pailet	1	Carbon steel
17	Water cup	1	Polyarbonate
16	O-ring	1	NBR
15	Drain board	1	ABS
14	Bolt	1	Carbon steel
13	Filter element	1	Brass
12	Whirling blade	1	ABS
11	Bowl guard	1	Carbon steel
10	Spring	1	Stainless steel
9	Lock	1	ABS
8	Pin	1	ABS
7	Nut	1	Brass
6	Hex Nut	1	Brass
5	O-ring	1	NBR
4	Drain valve	1	Brass
3	O-ring	1	NBR
2	Spring	1	Stainless steel
1	Valve core	1	Brass

EC
F.R.L

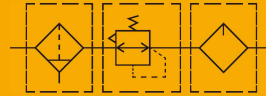

Specifications

Model	EC1000	EC2000	EC2500	EC3000	EC4000	EC5000
Proof pressure(MPa)	1.5					
Max. working pressure(MPa)	1.0					
Working temperature(°C)	-5-60 (No freezing)					
Filter precision	25 μm(5 μm is optional)					
Recommended oil	Turbine No.1 Oil ISOVG32					
Bowl material	Polycarbonate					
Bowl guard	None			Available		
Pressure adjusting range(MPa)	0.15-0.85					
Valve type	With overflow					

Model	Specifications							Accessories
	Filter	Regulator	Lubricator	* Rated flow (L/min)	** Port size (G)	Pressure gauge thread size (G)	Weight (kg)	
EC1000-M5	EF1000	ER1000	EL1000	90	M5	1/16	0.26	Y10L
EC2000-01	EF2000	ER2000	EL2000	1000	1/8	1/8	0.74	Y20L
EC2000-02				1100	1/4			
EC3000-02	EF3000	ER3000	EL3000	1950	1/4	1/8	1.18	Y30L
EC3000-03				2105	3/8			
EC4000-03	EF4000	ER4000	EL4000	4950	3/8	1/4	2.14	Y40L
EC4000-04				5200	1/2			
EC4000-06	EF4000-06	ER4000-06	EL4000-06	5600	3/4	1/4	2.47	Y50L
EC5000-06	EF5000	ER5000	EL5000	6200	3/4	1/4	3.82	Y60L
EC5000-10				6500	1			

* The above information is based on 8.0 Bar supply pressure and 6.3 Bar set pressure

* NPT,PT port size is optional

Main Dimension

EC1000-EC2000

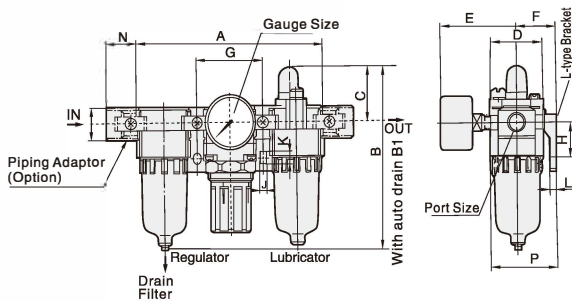

EC3000-EC5000

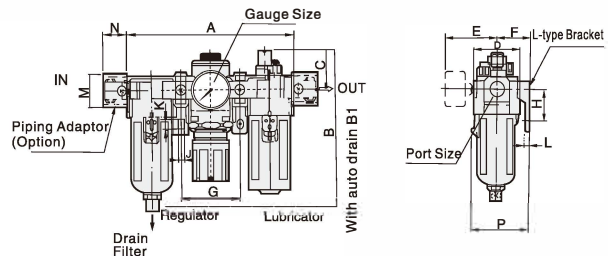

Model	Port Size (G)	A	B	B1	C	D	E	F	G	H	J	K	L	M	N	P
EC1000	M5	91	84.5	-	25.5	25	26	25	33	20	4.5	7.5	5	17.5	16	38.5
EC2000	1/8"-1/4"	140	123.5	161	37.5	40	53	30	50	24	5.5	8.5	5	22	23	50
EC3000	1/4"-3/8"	181	157.5	170	39	53	57	41	64	35	7.5	11	7.2	34.2	26	70.5
EC4000	3/8"-1/2"	238	190	194	40	70	62	50	84	40	9	13	7.2	42.2	33	88
EC4000-06	3/4"	253	191.5	194.5	39	70	66	50	89	40	9	13	7.2	46.2	36	88
EC5000	3/4"-1"	300	271.5	274.5	45.5	90	72	69.8	105	50	12	16	10.5	55.2	40	115