

# EXSW Series Slide Cylinder



## EXSW Slide Cylinder



### Specifications

Bore(mm)	16	20	25	32
Acting type	Double acting			
Working Medium	Clean Air(after 40 μ m filtration)			
Working Pressure (MPa)	0.1~1.0			
Guaranteed Pressure (MPa)	1.5			
Working Temperature (°C)	-20~80( No freezing)			
Speed range (mm/s)	30~500			
Cushion type	Rubber cushion			
Stroke tolerance(mm)	+1.0 0			
Adjustable stroke(mm)	-5~0			
No-rotating precision	±0.05°		±0.03°	
Port Size	M5 x 0.8		G1/8 ①	

① PT、NPT port size is optional.

### How to Order?

Series No	Type No	Bore X	Stroke	Magnet No	Thread Type
EXSW	M: Slide bearing	16 20 25 32	25 50 75 ...	S : With magnet	Blank: G P : PT T : NPT

#### Order Example:

EXSW series, Slide Bearing type, Bore 16mm, stroke 30mm ERP code is: EXSWM16X30-S

### Optional Accessories

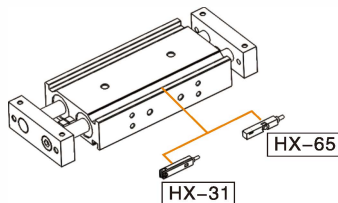

### Stroke

Bore (mm)	Standard Stroke (mm)	Max. Stroke (mm)
16-32	10 20 30 40 50 75 100 125 150	150

Note: Above chart shows standard stroke, for unstandard stroke, please contact with us.

### Internal Structure

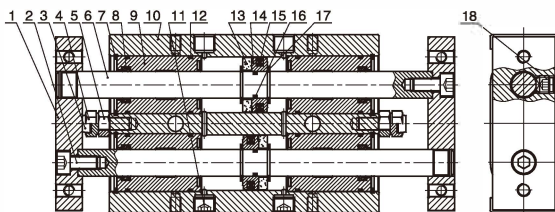

No.	Part Name	Material
1	Fixing plate	Aluminum alloy
2	Nut	Carbon steel
3	Bumper	POM
4	Adjustable nut	Carbon steel
5	Screw	Carbon steel
6	Piston rod	S45C hard chrome carbon steel
7	C clip	Spring steel
8	Wiper seal	NBR
9	Head cover	Aluminum alloy
10	Body	Aluminum alloy
11	Hex fix screw	Cu
12	O-ring	NBR
13	Magnet	Plastic
14	Piston	Aluminum alloy
15	Piston seal	NBR
16	O-ring	NBR
17	C clip	Spring steel
18	Nut	Carbon steel

## Main Dimension

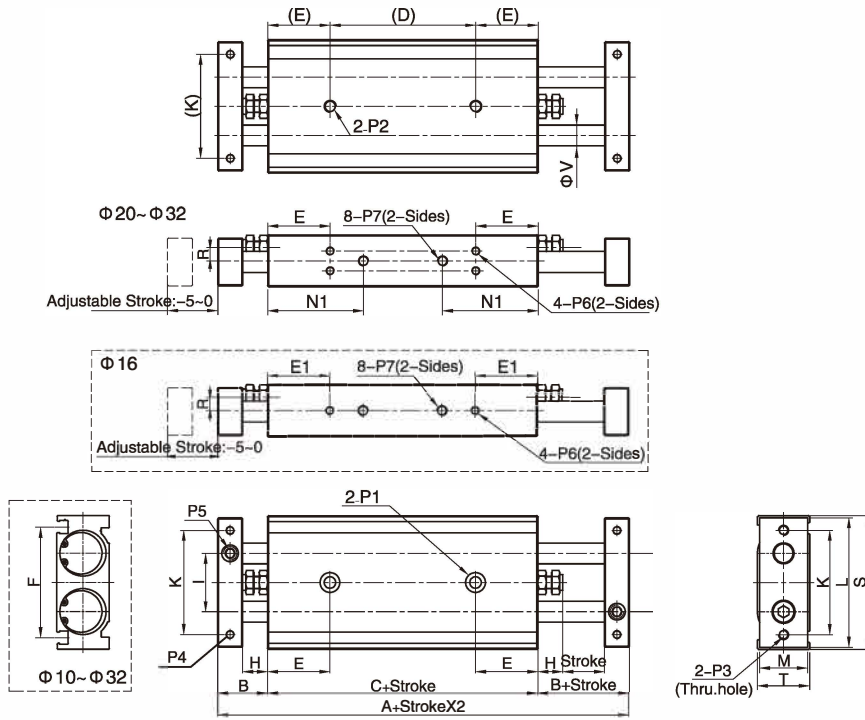

Bore\Sign	A	B	C	E	E1	F	H	I	K	L	M	N1	R	S	T	V	W
16	133	19	95	25	25	47.5	9	25	45	56	18	38	5	58	20	8	-
20	158	24	110	30	30	53	12	28	50	62	23	46	6.5	64	25	10	9.5
25	160	24	112	30	30	64	12	35	60	78	28	43	9	80	30	12	13
32	193	30	133	30	30	76	14	44	75	96	36	53	11.5	98	38	16	20
Bore\Sign	P1			P2			P3		P4		P5		P6		P7		
16	Φ8 Dp:4.4; Thru.hole: Φ4.3			M5X0.8 Dp:8			M5X0.8		M4X0.7		M6X1.0		M4X0.7 Dp:5		M5X0.8		
20	Φ9.5 Dp:5.3; Thru.hole: Φ5.2			M6X1.0 Dp:10			M5X0.8		M4X0.7 Dp:6		M8X1.25		M4X0.7 Dp:5.5		M5X0.8		
25	Φ11 Dp:6.3; Thru.hole: Φ6.8			M8X1.25 Dp:12			M6X1.0		M5X0.8 Dp:7.5		M8X1.25		M5X0.8 Dp:7		1/8"		
32	Φ11 Dp:6.3; Thru.hole: Φ6.8			M8X1.25 Dp:12			M6X1.0		M5X0.8 Dp:8		M10X1.5		M5X0.8 Dp:7		1/8"		

(mm)