

## How to Order?

Series No.	Type Code	Body Size	Combination QTY	Port Size	Drain Type	Pressure Gauge Code	Bracket Code	Scale Unit	Filter Precision	Thread Type
E: Round gauge series	C: Filter-regulator+ lubricator W: Filter-regulator F: Filter R: Regulator L: Lubricator	10: 1000 body 20: 2000 body 30: 3000 body 40: 4000 body 50: 5000 body	10: Two units (Regulator+Lubricator) 00: Others	1000 M5: M5 2000 01: 1/8" 02: 1/4" 03: 3/8"	4000 03: 3/8" 04: 1/2" 06: 3/4" 06: 3/4" 10: 1"	Blank: Manual drain type C: Semi-auto drain D: Auto Drain type	Blank: With bracket J: No bracket	Blank: 25 µm 5M: 5 µm 4: Mpa/Psi(Default) 5: Bar/Psi	Blank: 25 µm 5M: 5 µm	Blank: G P: PT T: NPT

### Order Example:

E series regulator, 2000 body size, 1/8 port size, with pressure gauge, with bracket, scale unit is Mpa/Psi, G thread, ERP code is: ER2000-01 4

## Air Preparation Unit Kits

### ER

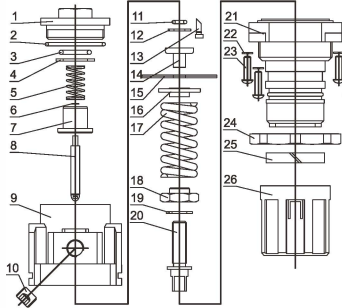

NO.	NAME	QTY	MATERIAL
26	Regulate handle	1	Reinforce nylon
25	Symbol ring	1	Reinforce nylon
24	Nut	1	Reinforce nylon
23	Crossscrew	4	Carbon steel
22	Spring washer	4	Carbon steel
21	Valve cover	1	Reinforce nylon
20	Regulate bolt	1	Carbon steel
19	Washer	1	POM
18	Regulate Nut	1	Carbon steel
17	Spring	1	Carbon steel
16	Springseat	1	Carbon steel
15	Diaphragm	1	NBR
14	Diaphragm seat	1	Brass
13	Pipe	1	POM
12	Retamer ring	1	Carbon steel
11	O-ring	1	NBR
10	Plug	1	Carbon steel
9	Valve body	1	Aluminum
8	Spool	1	Brass + NBR
7	Valve core	1	Brass
6	Retainerring	1	Carbon steel
5	Spring	1	Stainlesssteel
4	Washer	1	Carbon steel
3	O-ring	1	NBR
2	O-ring	1	NBR
1	Regulatorseat	1	ZZnAl4-1

### EF

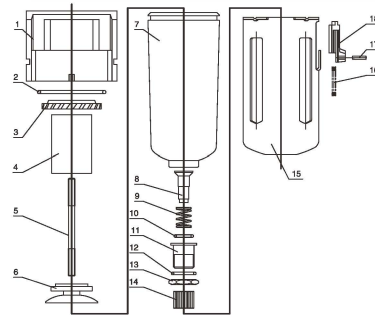

NO.	NAME	QTY	MATERIAL
18	Lock	1	ABS
17	Pin	1	ABS
16	Spring	1	Stainlesssteel
15	Metal bowl	1	Carbon steel
14	Nut	1	Cu
13	Hex Nut	1	Cu
12	O-ring	1	NBR
11	Drain valve	1	Cu
10	O-ring	1	NBR
9	Spring	1	Stainlesssteel
8	Valve core	1	Cu
7	Water cup	1	Polycarbonate
6	Drain board	1	ABS
5	Bolt	1	Carbon steel
4	Filterelement	1	Cu
3	Blade	1	ABS
2	O-ring	1	NBR
1	Regulatorbody	1	Aluminum

### EL

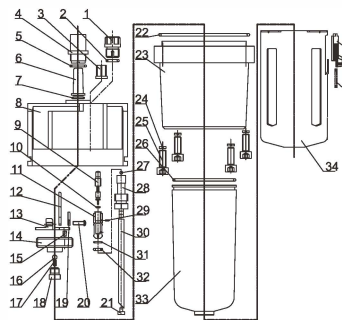

NO.	NAME	QTY	MATERIAL
37	Lock	1	ABS
36	Pin	1	ABS
35	Spring	1	Stainlesssteel
34	Bowlguard	1	Carbon steel
33	Oil cup	1	Polycarbonate
32	O-ring	1	NBR
31	O-ring	1	NBR
30	Oirtube	1	PU
29	Pin	1	Carbon steel
28	Fitting	1	POM
27	Steel ball	1	Carbon steel
26	O-ring	1	NBR
25	Hex screw	4	Carbon steel
24	Spring washer	4	Carbon steel
23	Middle part	1	Aluminum
22	O-ring	1	NBR
21	Filter element	1	Brass
20	Screw	2	Carbon steel
19	Needle seat board	1	ZZnAl4-1
18	One way valve plate	1	Cu
17	Spring	1	Stainless steel
16	Steel ball	1	Carbon steel
15	Small hoseat	1	Brass
14	Brascket	1	ZZnAl4-1
13	Reed seat	1	ZZnAl4-1
12	Reed	1	Polycarbonate
11	Oilregulate valve seat	1	Brass
10	O-ring	1	NBR
9	Regulate needle	1	Brass
8	Lubricator body	1	Aluminum
7	O-ring	1	NBR
6	Oil drip tube	1	Polycarbonate
5	O-ring	1	NBR
4	Oil window	1	Polycarbonate
3	Oil regulate screw	1	ABS
2	O-ring	1	NBR
1	Plug	1	ABS

### EW

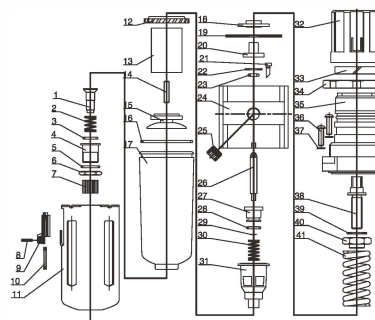

NO.	NAME	QTY	MATERIAL
41	Spring	1	Carbon steel
40	Regulate Nut	1	Carbon steel
39	Washer	1	POM
38	Regulate Bolt	1	Carbon steel
37	Spring washer	4	Carbon steel
36	Cross screw	4	Carbon steel
35	Valve cover	1	Reinforce nylon
34	Nut	1	Reinforce nylon
33	Symbol ring	1	Reinforce nylon
32	Regulate handle	1	Reinforce nylon
31	Overflow valve seat	1	ZZnAl4-1
30	Spring	1	Stainless steel
29	Retainerring	1	Carbon steel
28	O-ring	1	NBR
27	Valve core	1	Brass
26	Spool	1	Brass + NBR
25	Plug	1	Carbon steel
24	Regulatorbody	1	Aluminum
23	O-ring	1	NBR
22	Retainer ring	1	Carbon steel
21	Pipe	1	POM
20	Diaphragm seat	1	Brass
19	Diaphragm	1	NBR
18	Diaphragm Pallet	1	Carbon steel
17	Water cup	1	Polycarbonate
16	O-ring	1	NBR
15	Drain board	1	ABS
14	Bolt	1	Carbon steel
13	Filter element	1	Brass
12	Whirlwind blade	1	ABS
11	Bowl guard	1	Carbon steel
10	Spring	1	Stainless steel
9	Lock	1	ABS
8	Pin	1	ABS
7	Nut	1	Brass
6	Hex Nut	1	Brass
5	O-ring	1	NBR
4	Drain valve	1	NBR
3	O-ring	1	Brass
2	Spring	1	Stainless steel
1	Valve core	1	Brass

# EW Series Air Preparation Unit



**EW**  
F&R

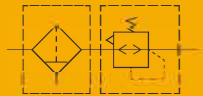

## Specifications

Model	EW1000	EW2000	EW3000	EW4000	EW5000
Proof pressure(MPa)	1.5				
Max. working pressure(MPa)	1.0				
Working temperature(°C)	5~60				
Filter precision	25µm (5µm is optional)				
Bowl material	Polycarbonate				
Bowl guard	None		Available		
Pressure adjusting range(MPa)	0.15~0.85				
Valve type	With overflow				

Model	Specifications				Accessories		Drain function	Auto drain model
	*Rated flow(L/min)	** Port size (G)	Pressure gauge thread size	Weight (kg)	Bracket			
EW1000-M5	100	M5	1/16	0.09	B120			
EW2000-01	1078	1/8	1/8	0.36	B220		EW2000-01D	
EW2000-02	1165	1/4				EW2000-02D		
EW3000-02	1998	1/4	1/8	0.56	B320		EW3000-02D	
EW3000-03	2177	3/8				EW3000-03D		
EW4000-03	5108	3/8	1/4	1.15	B420		EW4000-03D	
EW4000-04	5211	1/2				EW4000-04D		
EW4000-06	5750	3/4	1/4	1.21	B420		EW4000-06D	
EW5000-06	6200	3/4				EW5000-06D		
EW5000-10	6400	1	1/4	1.70			EW5000-10D	

## Main Dimension

### EW1000-EW2000

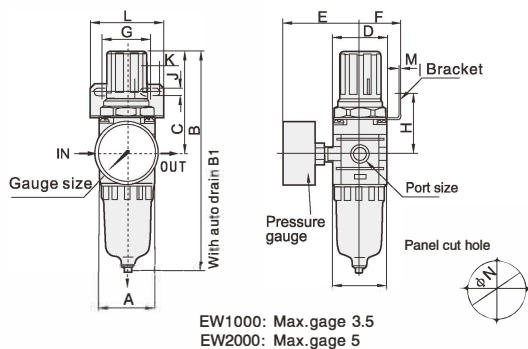

### EW3000-EW5000

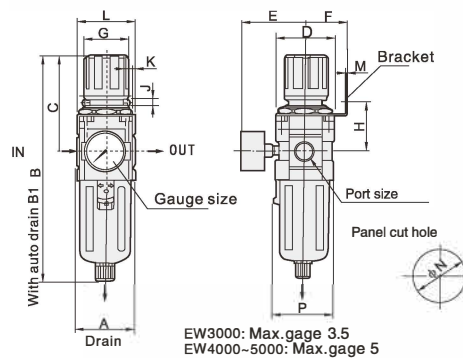

Model	Port Size (G)	A	B	B1	C	D	E	F	G	H	J	K	L	M	N	P
EW1000	M5	25	109.5	-	50.5	25	26	25	28	30	4.5	6.5	40	2	20.5	28
EW2000	1/8"-1/4"	40	162	200	76	40	53	30.5	33.5	43	5.4	15	55	2	33	40
EW3000	1/4"-3/8"	53	210.5	224.5	92	53	57	39	40	45	6.5	8	53	2	42	56
EW4000	3/8"-1/2"	70	264	267	113.5	70	67	48	53.5	53.5	8.5	10.5	70	2	52	73
EW4000-06	3/4"	75	268	271	115	70	67	48	53.5	53.5	8.5	10.5	70	2	52	73
EW5000	3/4"-1"	90	343	348	116.5	90	72	48	53.5	62	8.5	10.5	70	2	52	90