

EU Series Free Mount Cylinder



EU

Free Mount Cylinder



Specifications



Bore(mm)	6	10	16	20	25	32
Acting type	Double acting/Single acting					
Working medium	Clean air(40 μm filtration)					
Working pressure(MPa)	0.1~1.0(Double acting) / 0.2~1.0(Single acting)					
Guaranteed pressure(Mpa)	1.5					
Working temperature(°C)	-20~80(No freezing)					
Speed range(mm/s)	30~500					
Cushion type	Rubber cushion					
Port size	M5 x 0.8					G1/8"①

① PT、NPT port size is optional.

How to Order?

Series No	Type No	Bore	X Stroke	- Adjustable Stroke	- Magnet No	- Thread Type
EU	Blank: Basic type D: Double shaft type J: Double shaft and adjustable stroke type	6 10 16 ... 32	5 10 15 ... 80	10 20 30	Blank: No magnet S: With magnet	Blank: G P: PT T: NPT

Order Example:

EU Series basic type cylinder, 32mm bore, 30mm stroke, with magnet, NPT thread. ERP code is: EU32X30-S-T

Optional Accessories

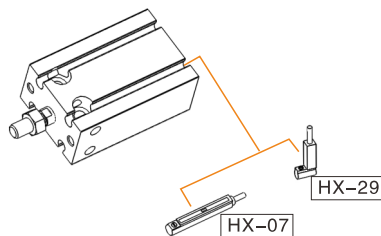

Note: Short stroke please use HX-29 series due to limited space.

Stroke

Bore (mm)	Standard Stroke (mm)										Max. Stroke (mm)
6	5	10	15	20	25	30	35				35
10	5	10	15	20	25	30	35	40			40
16	5	10	15	20	25	30	40	50	60		60
20	5	10	15	20	25	30	40	50	60	70	80
25	5	10	15	20	25	30	40	50	60	70	80
32	5	10	15	20	25	30	40	50	60	70	80

Note: 1. The maximum range of non – standard stroke is adjusted from the next longer stroke (add gasket inside), which has the same dimensions as the next longer stroke std. stroke cylinder. e.g. 23mm non – standard stroke cylinder is adjusted from 25 standard stroke cylinder, they have the same dimensions.
2. When ordering the stroke is greater than the Max. stroke, please contact the company.

Internal Structure

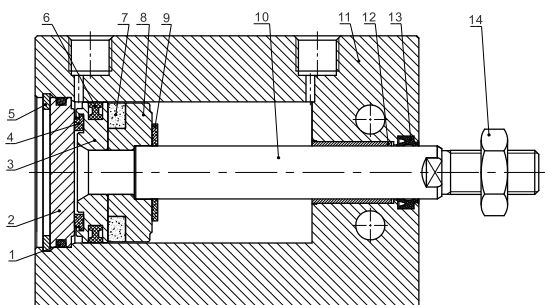

No.	Part Name	Material
1	O-ring	NBR
2	Rear cover	Aluminum alloy
3	Piston	Aluminum alloy
4	Anti-bump cushion	TPU
5	C type retainer ring	Spring steel
6	Piston seal	NBR
7	Magnet	NdFeB
8	Magnet base	Aluminum alloy
9	Anti-bump cushion	TPU/NBR
10	Piston rod	Stainless steel
11	Barrel	Aluminum alloy
12	Bearing	Compound material
13	Piston rod seal	TPU/NBR
14	Nut	Carbon steel

Installation

Parallel-shaft model (body connected)

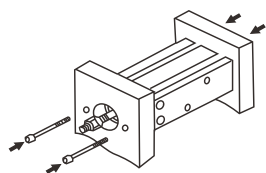

Vertical-shaft model (with through bore in the body)

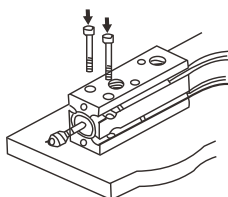

Side-connected (with through bore in the body)

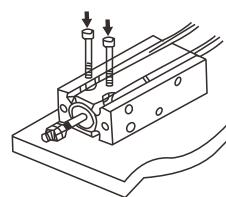

Main Dimension

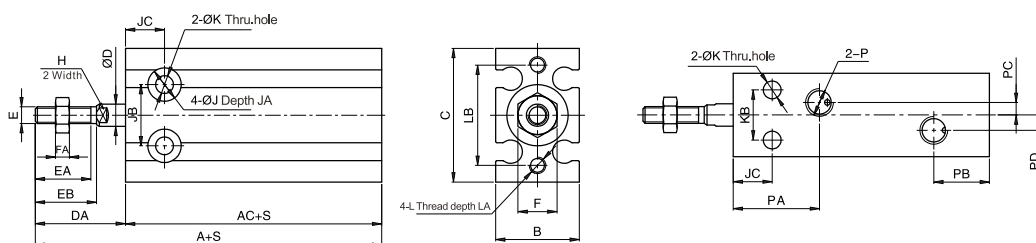

Bore/Sign	A(No magnet)	A(With magnet)	AC(No magnet)	AC(With magnet)	B	C	D	DA	E	EA	EB						
6	46	46	33	33	13	22	3	13	M3X0.5	7	8						
10	52	52	36	36	15	24	4	16	M4X0.7	10	11						
16	46	56	30	40	20	32	6	16	M5X0.8	11	12.5						
20	55	65	36	46	26	40	8	19	M6X1.0	12	14						
25	63	73	40	50	32	50	10	23	M8X1.25	15.5	18						
32	69	79	42	52	40	62	12	27	M10X1.25	19.5	22						
Bore/Sign	F	FA	H	J	JA	JB	JC	K	KB	L	LA	LB	P	PA	PB	PC	PD
6	5.5	2.5	-	5.8	4.5	10	7	3.2	7	M3X0.5	5	17	M5X0.8	15	10	-	-
10	7	3	-	5.8	4.8	11	7	3.2	9	M3X0.5	5	18	M5X0.8	15.5	10	-	-
16	8	4	5	7.5	6.5	14	7	4.3	12	M4X0.7	6	25	M5X0.8	15.5	11.5	2	2
20	10	5	6	9.5	8	16	9	5.5	16	M5X0.8	8	30	M5X0.8	21	10	4.5	5.5
25	12	6	8	9.5	9	20	10	5.5	20	M5X0.8	8	38	M5X0.8	23	10	4.5	6
32	17	6	10	11	11.5	24	11	6.6	24	M6X1.0	9	48	1/8"	23	12.5	4.5	9

Note: When bore is $\phi 6$ 、10mm, EU cylinder with double nuts.