

SQK

Rotary Clamp Cylinder



Specifications



Bore(mm)	16	20	25	32	40
Acting Type	Double Acting				
Working medium	Clean Air(40 μm filtration)				
Working pressure (MPa)	0.15~1.0(MPa)				
Guaranteed pressure (MPa)	1.5(MPa)				
Working temperature (°C)	-20~80(No freezing)				
Piston Speed (mm/s)	50~200				
Rotation angle	90° ± 10°				
Rotation Direction	Left rotation or right rotation				
Rotation Stroke (MM)	7.5	9.5		15	
Clamping stroke (MM)	10 20 30		10 20 30 50		
Stroke Tolerance	+1.0 0				
Cushion Type	Rubber cushion				
Port Size	M5x0.8			G1/8 ①	

① PT、NPT port size is optional.

How to Order?

Series No	Rotation Direction	Bore X Stroke	Magnet.No	Type No	Mounting Type	Thread Type
SQK	R:Right Rotation L:Left Rotation	16 10 20 20 25 30 32 50 40	S: With magnet Blank: Basic Type(with arm) J: No arm		Blank: No mounting	Blank: G P : PT T : NPT

Order Example:

SQK series basic type cylinder, bore 25mm, stroke20mm, right rotation, G thread, with arm, no mounting, ERP code is: SQKR25 × 20-S

Optional Accessories

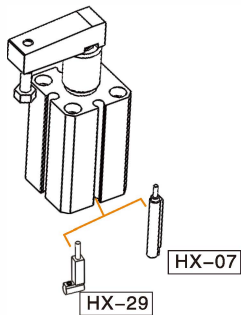

Note:Short stroke please use HX-29 series due to limited space.

Definition of Rotation Direction and Rotation Angle

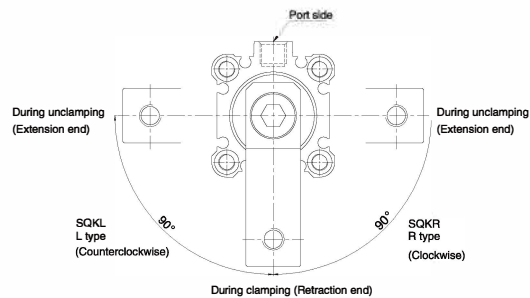

Stroke

	Bore(mm)	Clamping Stroke(mm)	Max.Clamping Stroke(mm)
Double acting	16、20、25	10 20 30	30
	32、40	10 20 30 50	50

SQK Series Rotary Clamp Cylinder



Internal Structure

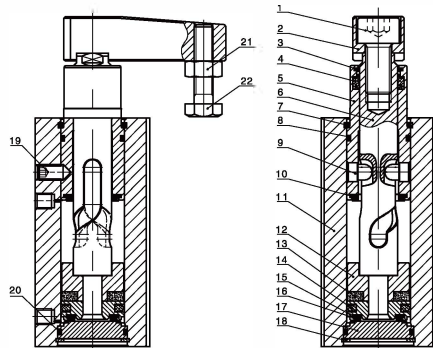

No.	Part Name	Material	No.	Part Name	Material
1	Hex Socket Cap Screw	Carbon steel	12	Magnet Base	Aluminium alloy
2	Clamping Arm	Steel	13	Integral Magnet	NdFeB/Plastic
3	Dust Scraping Ring	Free Machining Steel	14	Piston Seal	NBR
4	Piston Rod Seal	NBR	15	Piston	Aluminium alloy
5	Head Cover	Aluminium alloy	16	Anti-collision Gasket	PTEE
6	Piston Rod	Special material	17	Rear Cover	Aluminium alloy
7	Check Ring	Spring Steel/Stainless Steel	18	Check Ring for C Type Hole	Spring Steel
8	O-ring	NBR	19	Hex Socket Tighten Screw	Carbon steel
9	Rolling Stopper Pin	Special material	20	O-ring	NBR
10	Anti-collision Gasket	TPU	21	Hex Nut	Carbon steel
11	Barrel	Aluminium alloy	22	Hex bolt	Stainless Steel

Main Dimension

SQK $\Phi 16$

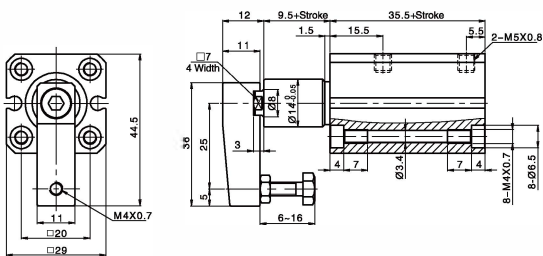

SQK $\Phi 20, \Phi 25$

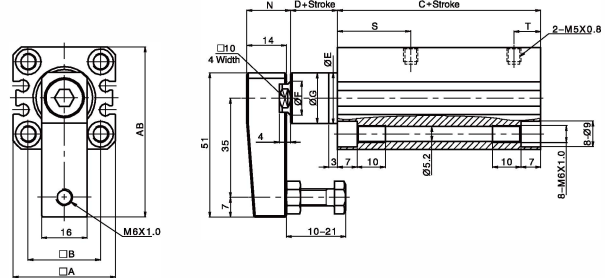

Bore/Sign	A	AB	B	C	D	E	F	G	N	S	T
20	36	60	25.5	62	6.5	18.9 _{0.08}	12	17.9	15.5	26	9.5
25	40	62	28	63	6.5	23.9 _{0.06}	12	22.5	15.5	27.5	10

SQK $\Phi 32, \Phi 40$

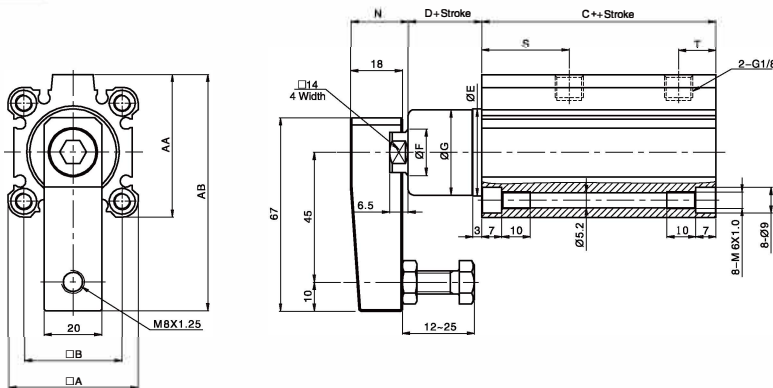

Bore/Sign	A	AA	AB	B	C	D	E	F	G	N	S	T
32	45	49.5	82	34	71.5	15.5	30.9 _{0.08}	16	29.5	20	30.5	13
40	52	51	86	40	65	23	30.9 _{0.06}	16	29.5	20	27.5	8

Installation and Use

1. Dirty substances in the pipe must be eliminated before cylinder is connected with pipeline to prevent the entrance of impurities into the cylinder.
2. The medium used by cylinder shall be filtered to 40 μ m or below.
3. Anti-freezing measure shall be adopted under low temperature environment to prevent moisture freezing.
4. If the cylinder is dismantled and stored for a long time, please conduct anti-rust treatment to the surface. Anti-dust jam cap shall be added in air inlet and outlet ports.
5. To insure the life-span of cylinder and jig, please use flow control valve to control the speed of cylinder.
6. The method of installation are mounted by flange on top or bottom.

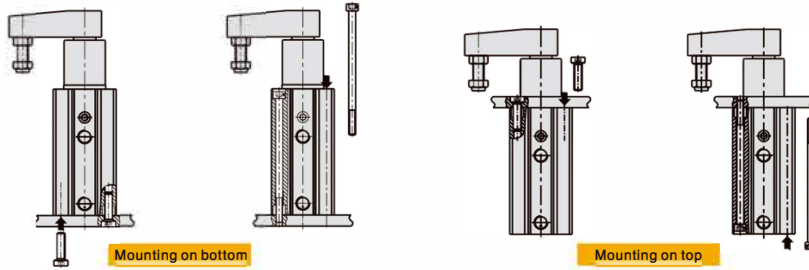

7. Please clean the piston rod and dust scraping ring to protect the cylinder.
8. Magnetic switch of SQK is same as SQ series cylinder.
9. Please install the cylinder as below diagram.

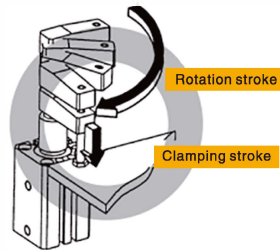

10. The installation method as the diagram below is wrong, and will injure the cylinder and shorten the cylinder life.

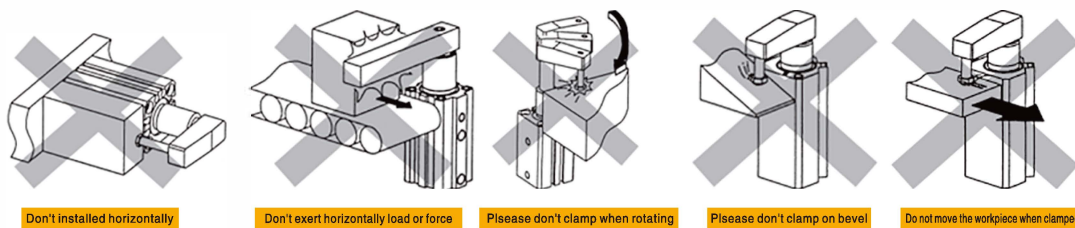

11. Please follow the diagram below on right side to assemble/disassemble the rocker by spanner and allen wrench, don't hold the body to assemble /diassemble rocker, or will damage the cylinder.

